

# BASEL - Stufe/ Tread/ Trin

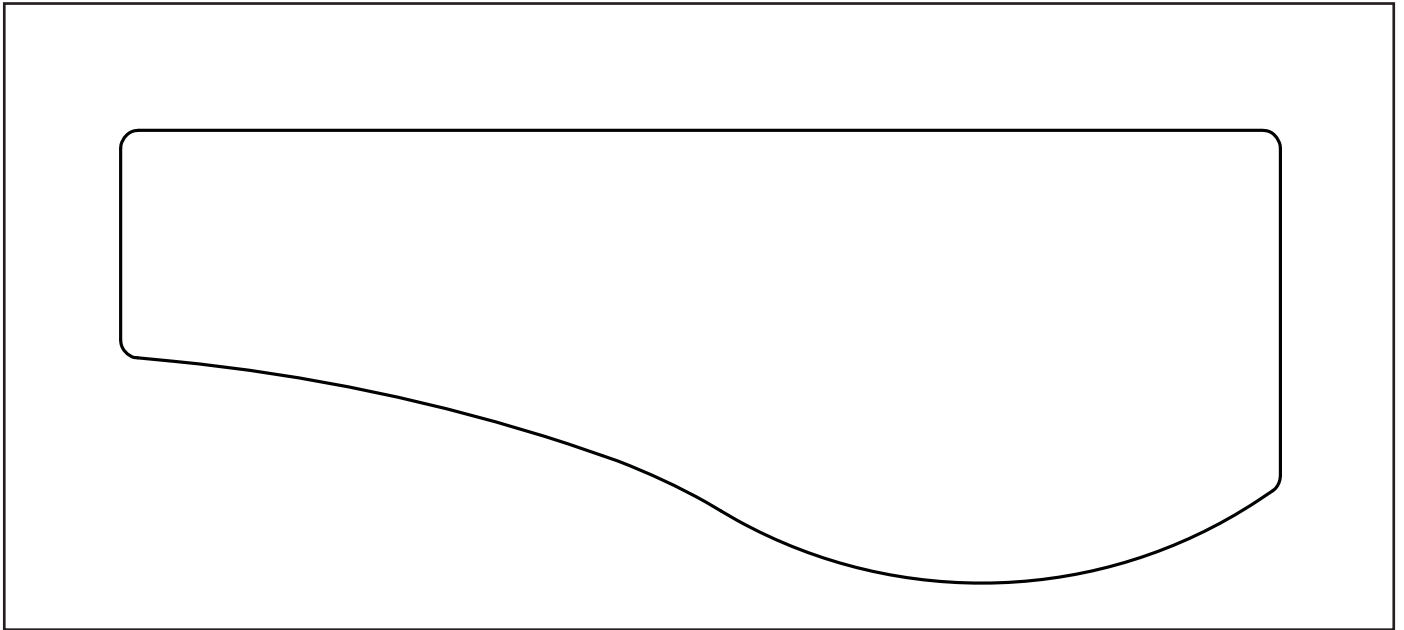

**Vorbereitung (A)**

- Wahl des Grundrisses - siehe Beispiele (Seite 6)
- Steigungshöhe aufgrund fgl. Formel ermitteln:  $\frac{\text{Geschosshöhe}}{\text{Anzahl Stufen} + 1} = \underline{\underline{\text{Steigungshöhe}}}$
- Ist der Drehwinkel zweier aufeinander folgender Stufen größer als  $20^\circ$ , so ist es sinnvoll, die Stufen gleich auszurichten - siehe Abb. (A2).

**Montage (Abbildungen 1-14)**

ACHTUNG - Die Treppe von OBEN nach UNTEN montieren!

- Beginn der Treppenmontage - Ausgangspunkt: Abb. 1 (Seite 7).
- UNBEDINGT die Steigungshöhe jeder Stufe überprüfen!
- UNBEDINGT eine Abstützung nach Montage der ersten 4 Elemente anbringen  
- siehe Abb. 3 (Seite 7).

Abb. (4): VOR der Montage der letzten 2 Elemente diese wie in der Abb. gezeigt zusammen stecken - OHNE sie festzuziehen. Elemente anschl. in der Konstruktion in Position bringen und die Steigungshöhe justieren.

Abb. (7): Montage der Stufen:  
Die breite Seite der obersten Stufe zur Geländerseite hin ausrichten. Anschließend die Stufen abwärts im Wechsel rechts und links montieren.

HINWEIS: Am einfachsten ist es, vor Montage der Stufen diese für das Geländer vorzubohren. Hierfür die mitgelieferte Schablone nutzen - auf Seite 10.

Die Stufen mittig auf dem Element platzieren; Abstand (X), siehe Abb. (7), und Abstand (Y), siehe Abb. (8), kontrollieren.

HINWEIS: Ist der Drehwinkel zweier aufeinander folgender Stufen größer als  $20^\circ$ , so ist es sinnvoll, die Stufen gleich auszurichten - siehe Abb. (A2) - auf Seite 6.

Abb. (9-13), (14):

Montage des Geländers:

An der obersten Stufe beginnen; anschl. die Geländerpfosten an jeder 2. Stufe montieren. Den Austrittspfosten auf dem Boden des Obergeschosses montieren, danach den Handlauf und zuletzt das Stahseil Abb (14) befestigen.

ACHTUNG: Es ist wichtig, dass der GESAMTE Handlauf VOR dem Anziehen des Stahlseils montiert worden ist.

## Preparation (A)

- Choose the required floor plan – see examples.
- Calculate the height of rise using the following formula:  $\frac{\text{floor height}}{\text{number of steps} + 1} = \underline{\underline{\text{height of rise}}}$
- If the angle of two successive steps is greater than  $20^{\circ}$ , the steps may be turned the same way – see Figure (A2).

## Assembly Figur (1-14)

NB! The staircase should be assembled from the TOP DOWNWARDS.

- Start assembling the staircase – begin with figure (1).
- REMEMBER to check the height of rise for every step.
- REMEMBER to use support once the first four elements have been assembled – see Figure (3).

Figure (4): Assemble the last two elements as shown in the figure BEFORE installing them – but DO NOT tighten.  
Next, insert in the correct place and adjust the height of rise.

Figure (7): Installing the steps:  
Turn the wide side of the top step towards the handrail. Next, install the steps working downwards, alternating right and left.

NB! It is easier to pre-drill the steps for the railing prior to installation.  
Use the enclosed template - at page 8.  
Place the steps in the middle of the support, check distance (X) – see Figure (7) and distance (Y) – see Figure (8).

NB! If the angle of two successive steps is greater than  $20^{\circ}$ , the steps may be turned the same way – see Figure (A2) at page 6.

Figure (9–13), (14):  
Installing the handrail:  
Start at the top step and affix the railing to every second step.  
Attach the landing rail to the floor, then fit the handrail and finally the steel wire – see Figure (14).

NB! You must install the ENTIRE handrail BEFORE tightening the steel wire.

## Forberedelse (A)

- Valg af grundplan - se eksempler
- Stigningshøjden beregnes ud fra flg. formel: 
$$\frac{\text{etagehøjde}}{\text{antal trin} + 1} = \underline{\underline{\text{stigningshøjde}}}$$
- Hvis vinklen på 2 på hinanden følgende trin er større end  $20^{\circ}$ , kan trinene med fordel vendes ens - se figur (A2)

## Montage - Figur (1-14)

### OBS - Trappen monteres **OPPEFRA** og **NED**

- Begynd montagen af trappen - start ved figur (1)
- HUSK at kontrollere stigningshøjde for hvert trin
- HUSK understøtning når de første 4 elementer er monteret - se figur (3)

Figur (4): FØR de 2 sidste elementer monteres, samles disse, som vist på figuren  
- UDEN at spænde dem sammen. Herefter skydes disse på plads i konstruktionen og stigningshøjden justeres.

Figur (7): Montage af trin:  
Toptrinnet vendes med den brede side, hvor gelænderet skal stå. Herefter monteres trinene nedefter skiftevis højre og venstre.

OBS - det er lettest at forbore trinene til gelænder, før de monteres. Anvend vedlagte skabelon - side 8.

Trinene placeres midt på bæringen, kontroller afstand (X) se figur (7) og afstand (Y) se figur (8).

BEMÆRK: Hvis vinklen på 2 på hinanden følgende trin er større end  $20^{\circ}$ , kan trinene med fordel vendes ens - ses på figur (A2) på side 6.











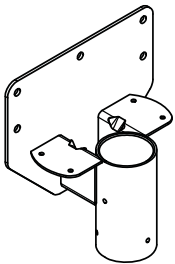
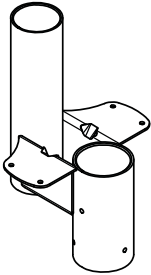
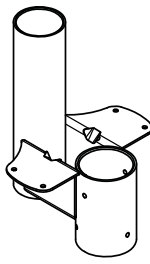
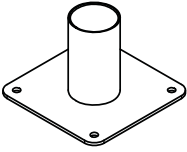
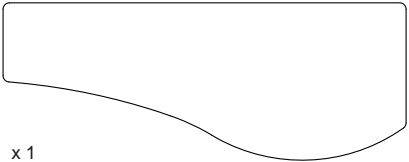

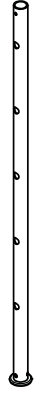



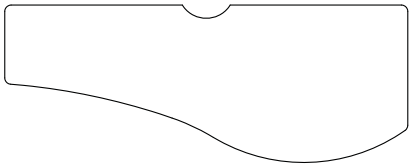





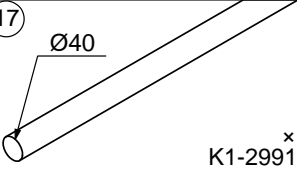



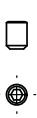

Figur (9-13), (14):

Montage af gelænder:

Start ved toptrinnet, herefter monteres balusteren på hvert 2. trin.

Reposbaluster monteres på dæk, derefter monteres håndliste og tilsidst monteres stålwire figur (14)

**OBS:** Det er vigtigt at HELE håndlisten er monteret FØR stålwire strammes.

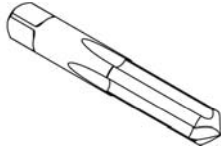
<p>①</p>  <p>x 1 K2-29240</p>	<p>②</p>  <p>x 9 K2-29230</p>	<p>③</p>  <p>x 1 K2-29270</p>	<p>④</p>  <p>x 1 K2-29250</p>				
<p>⑤</p>  <p>x 1 K1-28050</p>	<p>⑦</p>  <p>x 1 K2-29281</p>	<p>⑧</p>  <p>x 6 K2-29280</p>	<p>⑨</p>  <p>x 7 K1-29204</p>	<p>⑩</p>  <p>x 7 K1-12207</p>	<p>⑪</p>  <p>x 2 K2-01020</p>		
<p>⑥</p>  <p>x 10 K1-28060</p>	<p>⑫</p>  <p>x 6 K2-01010</p>	<p>⑬</p>  <p>x 1 K1-01620</p>	<p>⑭</p>  <p>x 10 K2-04200</p>	<p>⑮</p>  <p>x 35 k1-04041</p>	<p>⑯</p>  <p>18 m K1-23292</p>		
<p>⑰</p>  <p>Ø40 x 3 K1-29915</p>							
<p>④①</p>  <p>x 9 K3-08004 Ø10x60</p>	<p>④②</p>  <p>x 9 K3-04028 Ø8</p>	<p>④③</p>  <p>x 9 K3-06015 Ø8x70</p>	<p>④④</p>  <p>x 55 K3-05003 M8x6</p>	<p>④⑤</p>  <p>x 44 K3-06030 Ø6x30</p>	<p>④⑥</p>  <p>x 3 K3-08002 Ø8x40</p>	<p>④⑦</p>  <p>x 3 K3-06022 Ø5x35</p>	<p>④⑧</p>  <p>x 7 K3-05060 M6x8</p>
<p>④⑨</p>  <p>x 7 K3-01002 M5x18</p>	<p>④⑩</p>  <p>x 7 K3-03020 M5</p>	<p>④⑪</p>  <p>x 14 K3-06018 Ø4x25</p>	<p>④⑫</p>  <p>x 6 K3-07008 M10x70</p>	<p>④⑬</p>  <p>x 6 K3-04030 Ø10</p>	<p>④⑭</p>  <p>x 6 K3-03010 M10</p>	<p>④⑮</p>  <p>x 35 K1-04040 M6x18</p>	<p>④⑯</p>  <p>x 14 K3-06064 Ø4x25</p>
<p><b>D</b></p>	<p>Bitte beachten Sie, dass sich auf Grund der Beschichtung Rückstände in den Bohrlochern bilden können. Zu deren Beseitigung benutzen Sie bitte den beiliegenden Gewindebohrer.</p>						
<p><b>GB</b></p>	<p>Please note that impurities may occur in the threads of the components. We have enclosed a screw tap for correction of this.</p>						<p>x 1 K3 10010</p>
<p><b>DK</b></p>	<p>Bemærk venligst at der kan forekomme urenheder i komponenternes gevind. Vi har vedlagt en snittap til udbedring af dette.</p>						

**A**

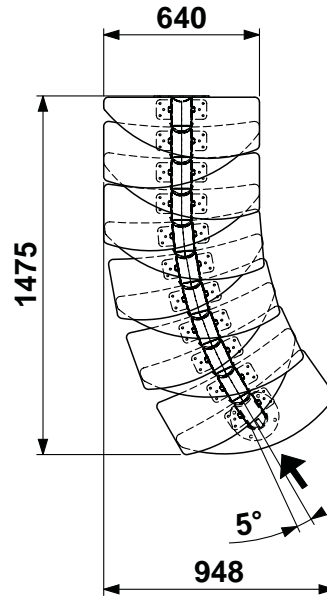
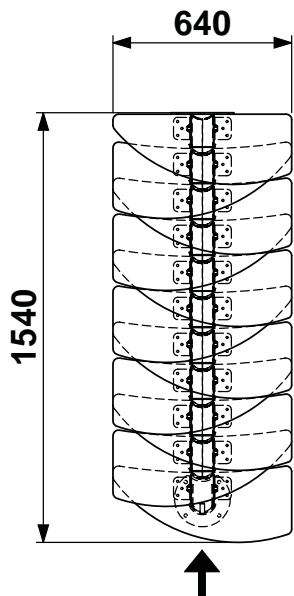

**A2**

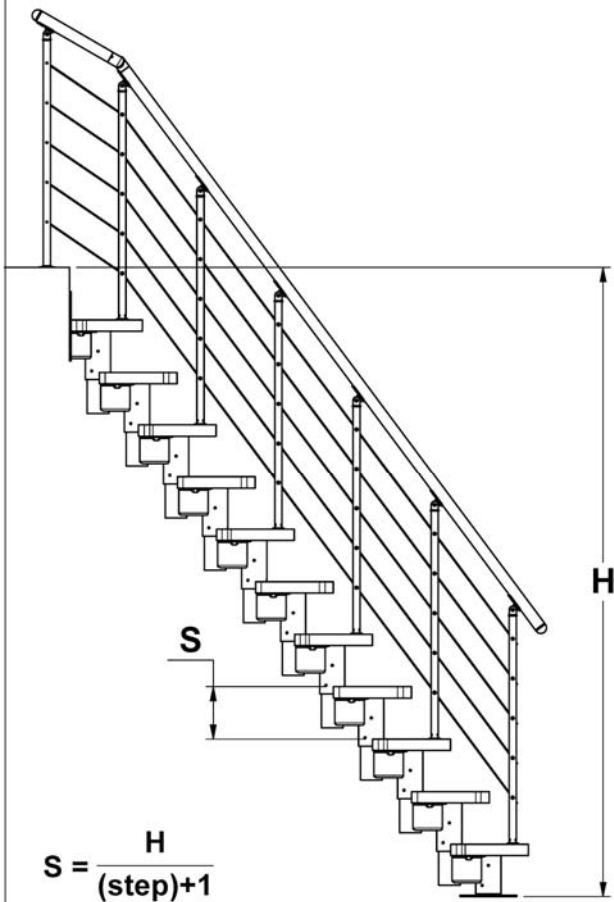
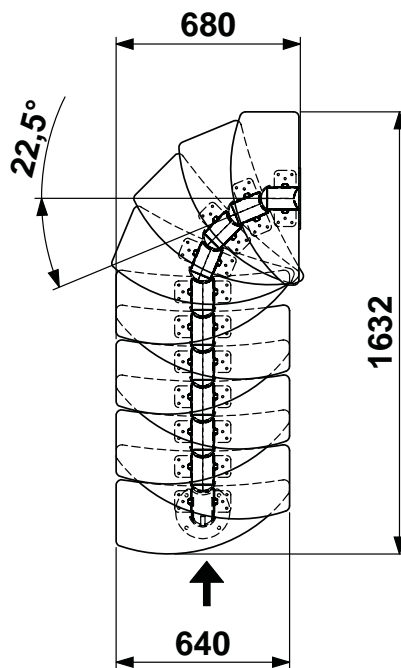
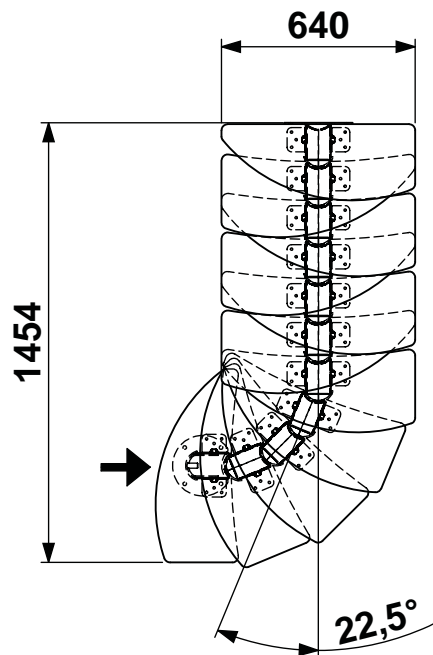

$$S = \frac{H}{(\text{step})+1}$$

**A1**

<b>S min</b>	185	mm
<b>S max</b>	230	mm
<b>(step)+1</b>	<b>H min</b>	<b>H max</b>
	mm	mm
12	2220	2760
13	2405	2990
14	2590	3220
15	2775	max 3450

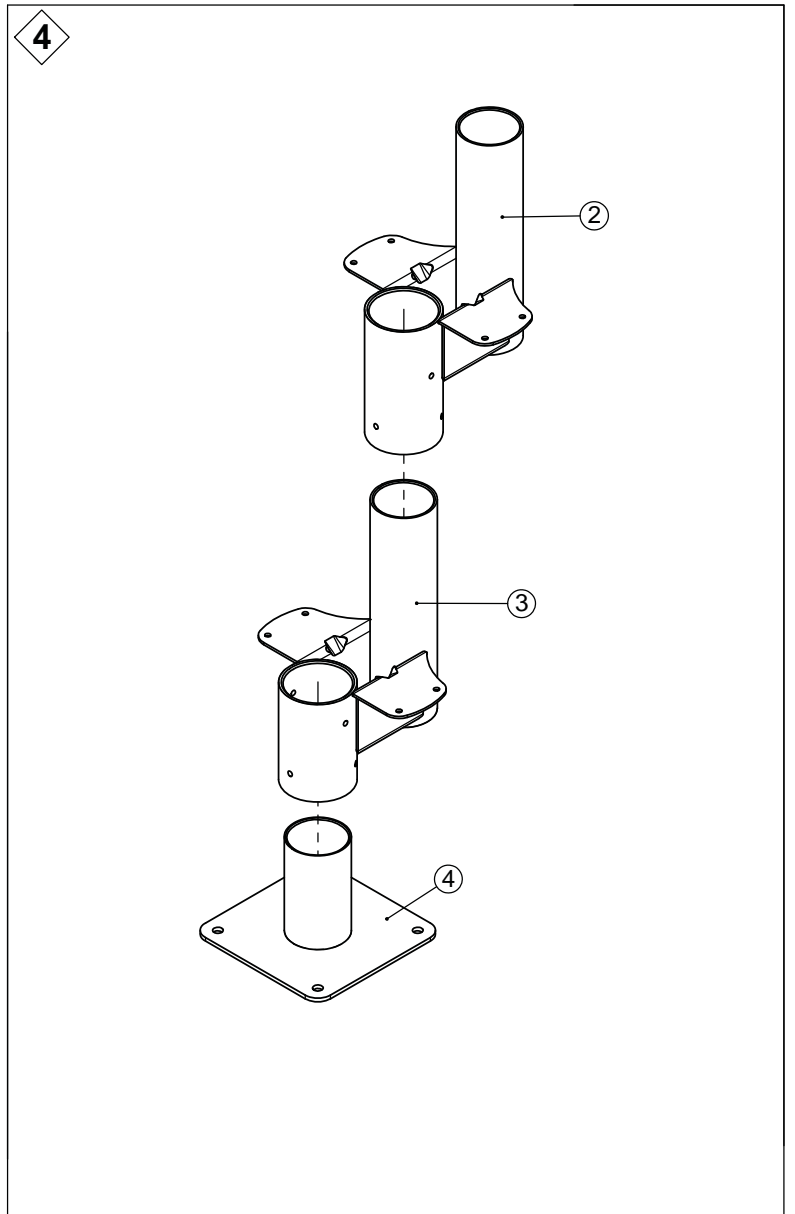
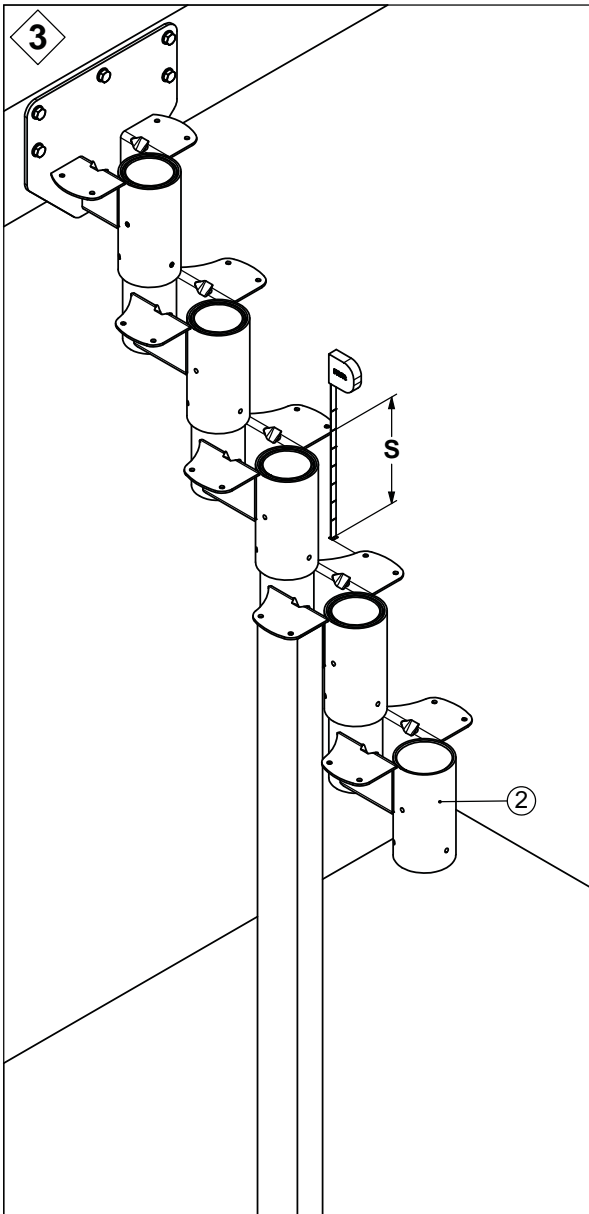
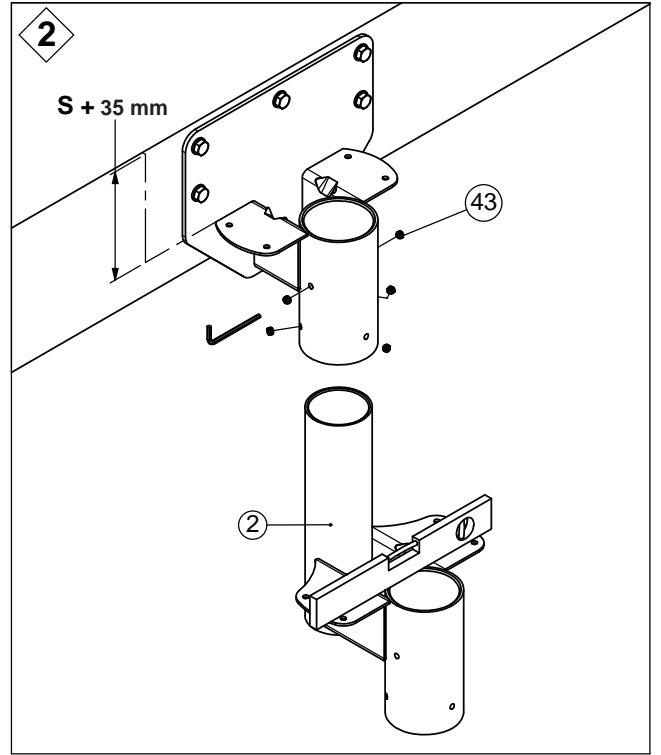
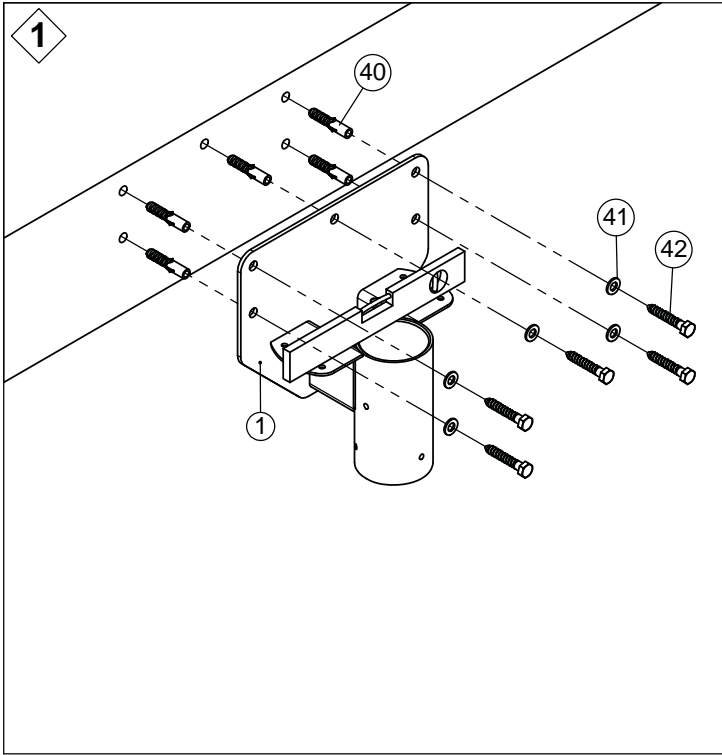



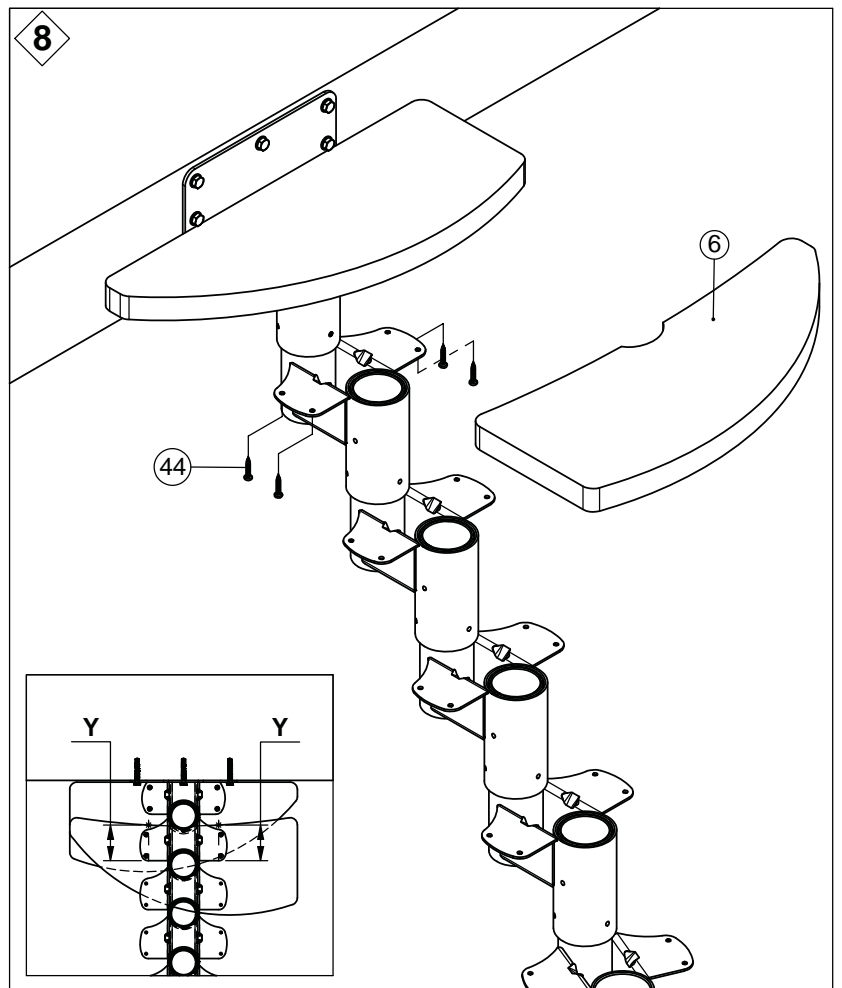
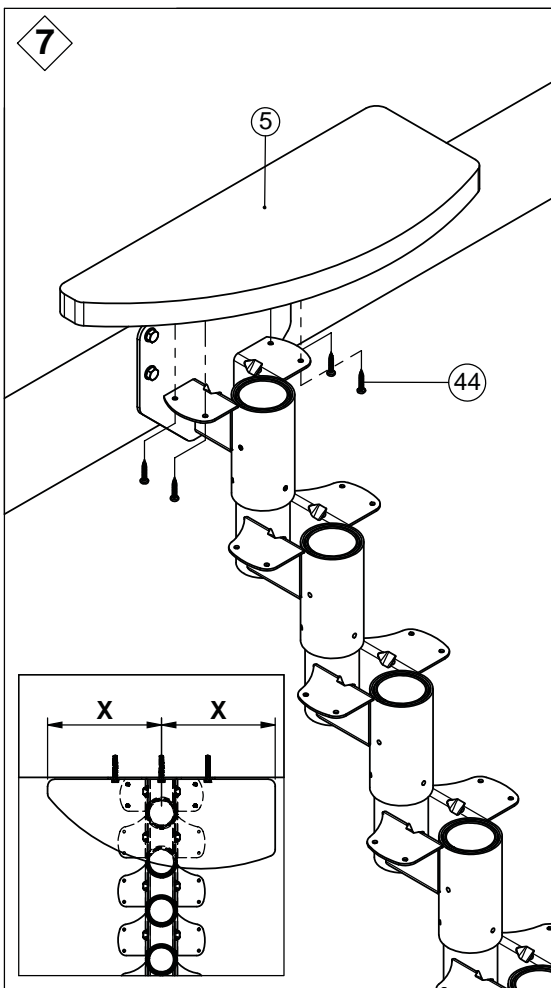
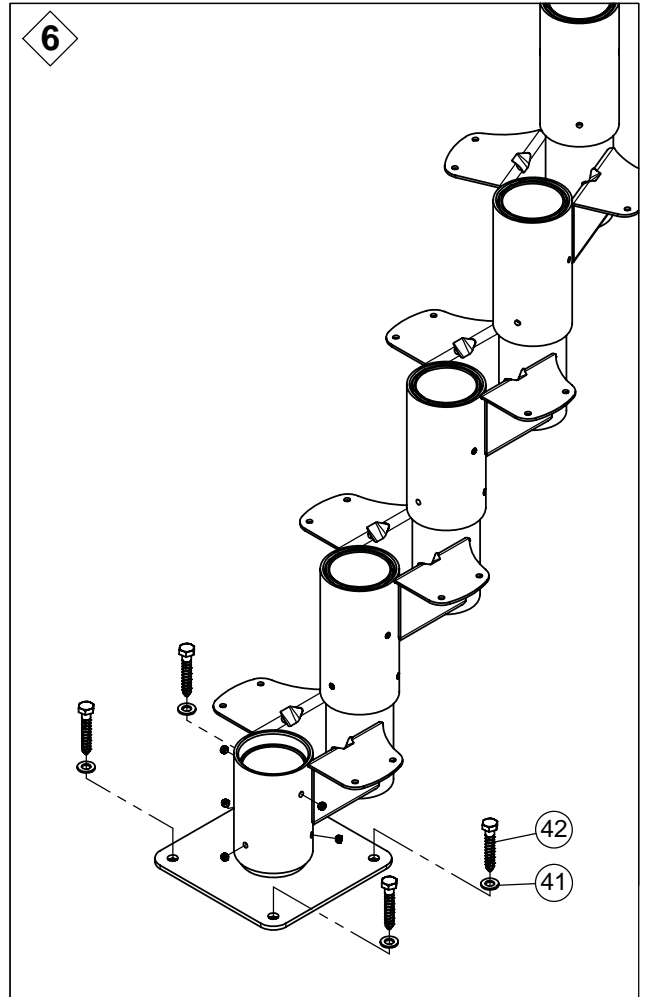
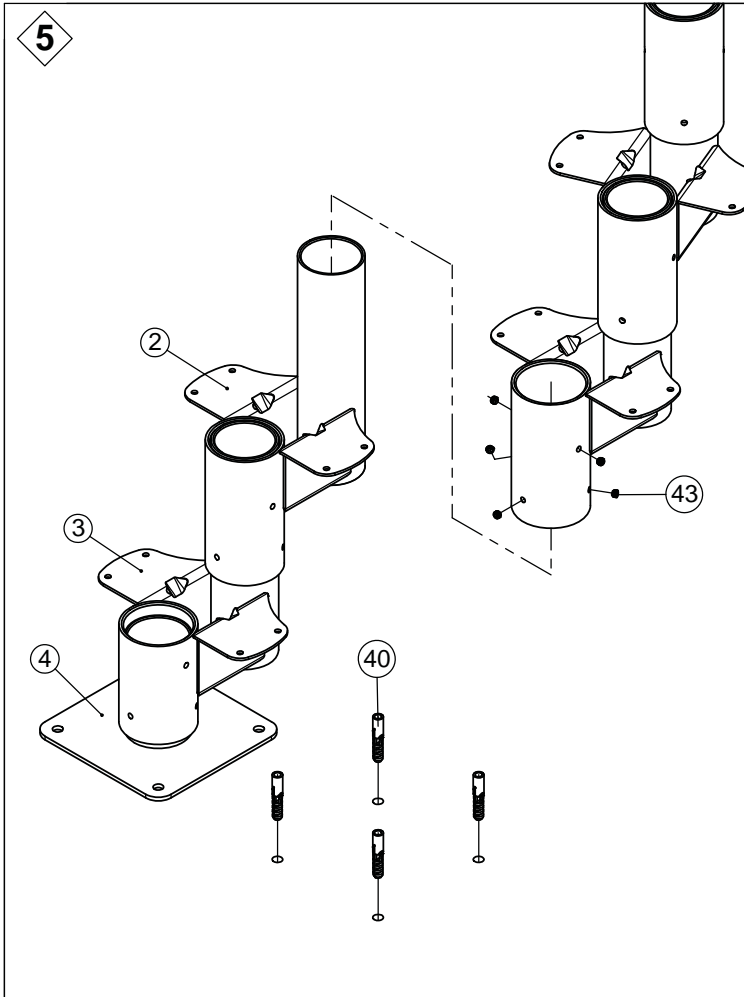

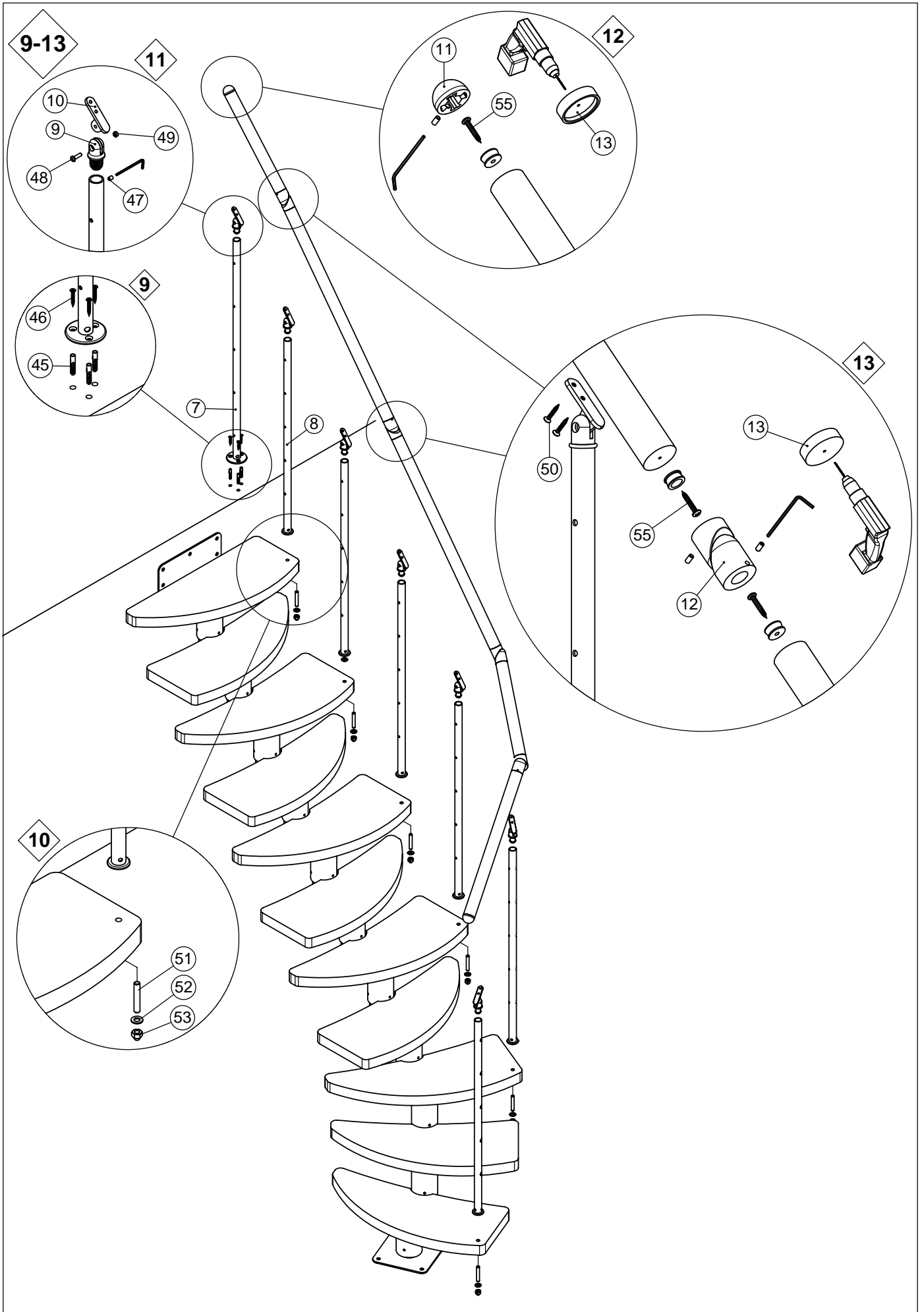

R1-99880-08

14

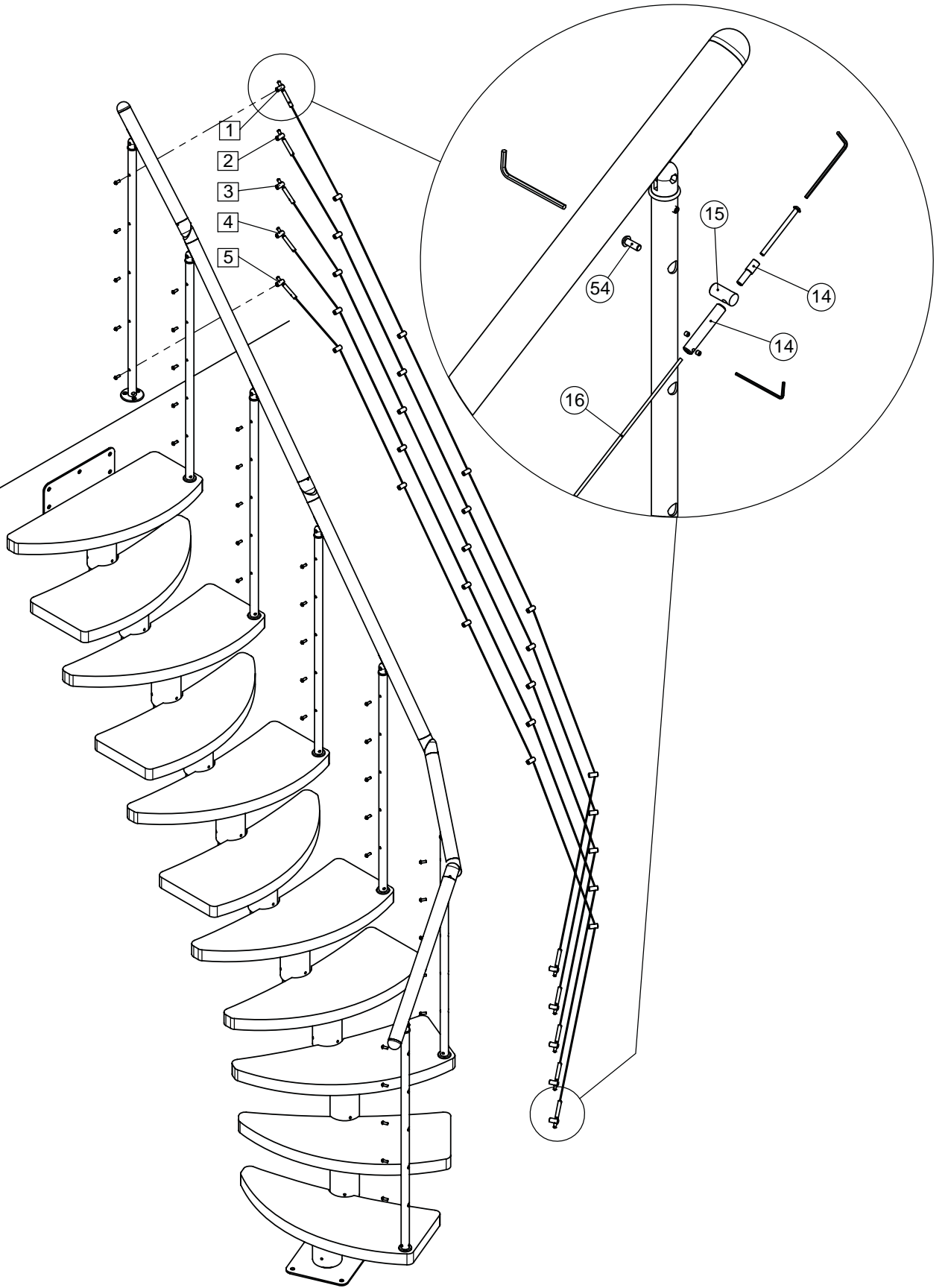

Ø 11 mm

